

LINEAR CARD SACCOR

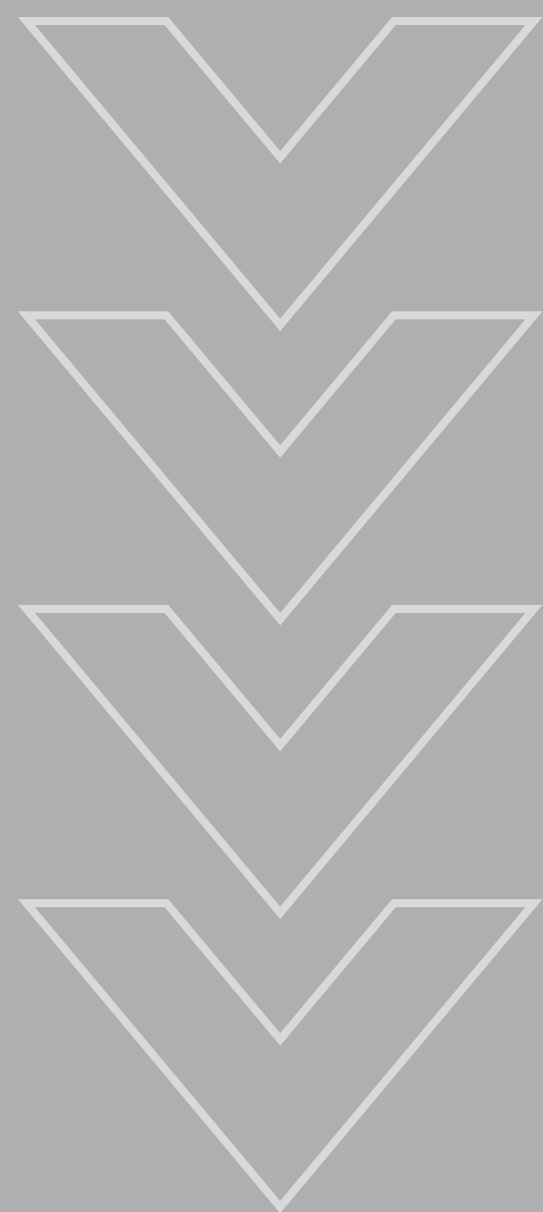

ABOUT US:

SACICORP AUTOMATION:

SACICORP is one of three joint companies specializing in industrial sector services. We offer a wide range of products and services through which we provide automation solutions and safety measures tailored to your projects.

Our main goal is to deliver excellent service by implementing top-tier, high-quality products, with the intention of exceeding our customer's expectations.

1

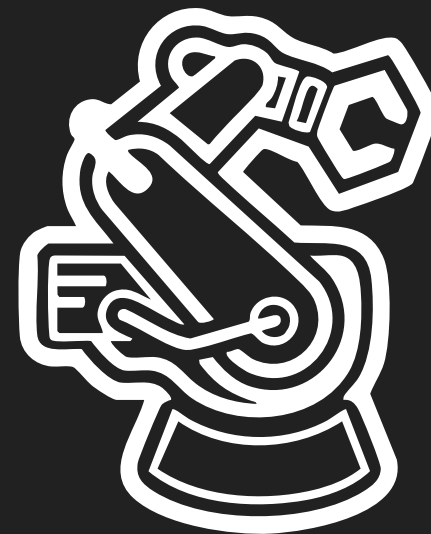

SACI CORPORATION

SACICORP AUTOMATION S.A.
DE C.V.

RFC: SCA200817782

Its main activities are managing, administration, purchasing and supply sales.

2



SACI MACHINING

TECNOLOGÍA EN EXTRUSIÓN
DE ALUMINIO Y SOLUCIONES
INDUSTRIALES S.A. DE C.V

RFC: TEA170315R78

Its main activities are: machining, industrial design, and aluminium profiles sales.

3



SACI AUTOMATION

JOSE FRANCISCO FRANCO
DUARTE

RFC: FADF780415CF8

Its main activities are general engineering, automation services and integrations.

ENGINEERING APPLICATIONS:

1. **Automation Solutions:** Workstations, production lines, introduction to 4.0 Industry, metrology through vision systems, pneumatic and hydraulic systems.
2. **Integration Systems:** Updates and renewals to industrial systems, poka-yoke and laser sensors.
3. **Software development:** Industrial sector oriented apps, software analysis and problem solving.
4. **Control:** Programmable Logic Controller (PLC) updates, electric control and design, HMI programming.

SERVICES:



1. **Consulting services** and training for industrial equipment.
2. **Development and solutions**, process improvement and standardization.
3. **Maintenance services** and industrial repairs.

MANUFACTURING:

1. **CAD/CAM:** Structural analysis, drawings and blueprints, 3D simulations.
2. **Metalworking:** CNC Machining (Vertical Control), Laser, EDM wire-cutting, welding processes, etc.

SERVICES:

- Automation services
- Software development
- Process customization
- Electronic repairs
- Maquinado CNC con certificación de metrología
- Metalmechanical manufacturing
- CAD/CAM Design
- System integrations
- Machinery manufacturing
- Manufacturing
- Electrical repair



ERP PORTAL:

ERP: ENTERPRISE RESOURCE PLANNING

SACICORP, characterized by constant innovation, has within its processes a management system called SACIONLINE, which allows us to offer you continuous assistance and monitoring of your projects.

Intertwined with SACICORP collaborators work e-mail accounts, it can be used remotely from every part of the world, which makes it an efficient product for internal control and secure use management of corporative data.

- Administration
- Purchasing & sales
- Design
- Machining
- Engineering



Recursos Humanos

- Employee Registry
- Incident reports
- Overtime
- Vacations
- Training courses
- Complaints & suggestions inbox



Compras

- Supplier list
- Shopping cart
- Purchasing management
- Accounts payable
- Purchase orders



Ventas

- Customer portfolio
- Sales order
- Receivable bills
- Sales representatives
- Quotations



Administración

- Finances
- Accounting



Ingeniería

- OC projects
- Design
- Machining
- Quality contro;



Almacen

- Storage
- Inventory management

SOLUTIONS

IN AUTOMATION

We are a specialized group in automation problem solving, dedicated to reduce costs, striving towards optimal efficiency in production while looking out for quality work improvement and safety for you, your collaborators and your company.



1
Equipment fabrication
process

2
Document control

3
Post-sale service,
supplies & support

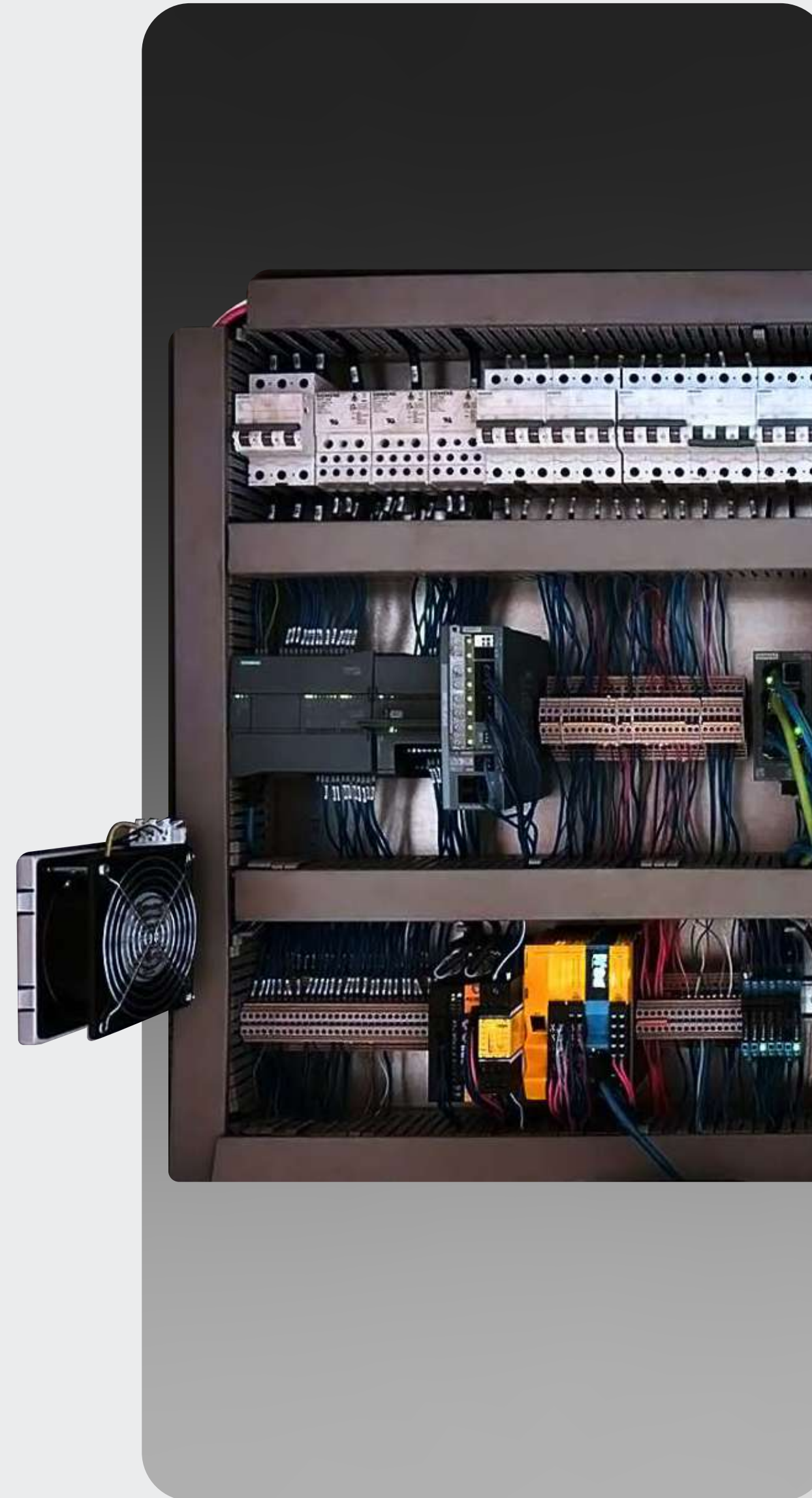



SOFTWARE

DEVELOPMENT

We provide software services, automation related solutions and process monitoring such as:
Data-collecting apps, instrumental control and instrumentalization testing.

Mastering following devices and software development tools for integration systems:

PLC HMI Drivers Teach Panels

Labview C# HTML SQL

QUALITY PROCESSES:

SACICORP has verifiable quality processes, fervently achieving required standards, norms and quality criteria, to ensure we provide our customers the best products available for their companies.

INTEGRATIONS:

SACICORP provides technical services and the necessary resources to create manufacturing projects, from conceptualization till its completion, achieving functional and unified systems.

CERTIFICATIONS:

SACICORP received: 'Bronze System integrator - a Rockwell Automation partner' by Rockwell Automation, as well as 'Dassault Systems CAD DESIGN - solidworks professional' by Dassault Systems, certifications



DESIGN:

Our personal is highly qualified in the use of digital design software and tools, carefully maintaining high standards required by our customers, while actively looking for smart, creative and efficient design solutions.

AutoCAD Autodesk AutoCAD

Solidworks MasterCAM

WE USE THE BEST BRANDS AVAILABLE AND WE HANDLE DESIGN SOFTWARE SUCH AS:





SACI MACHINING

IN SACI MACHINING OUR SPECIALTY IS:

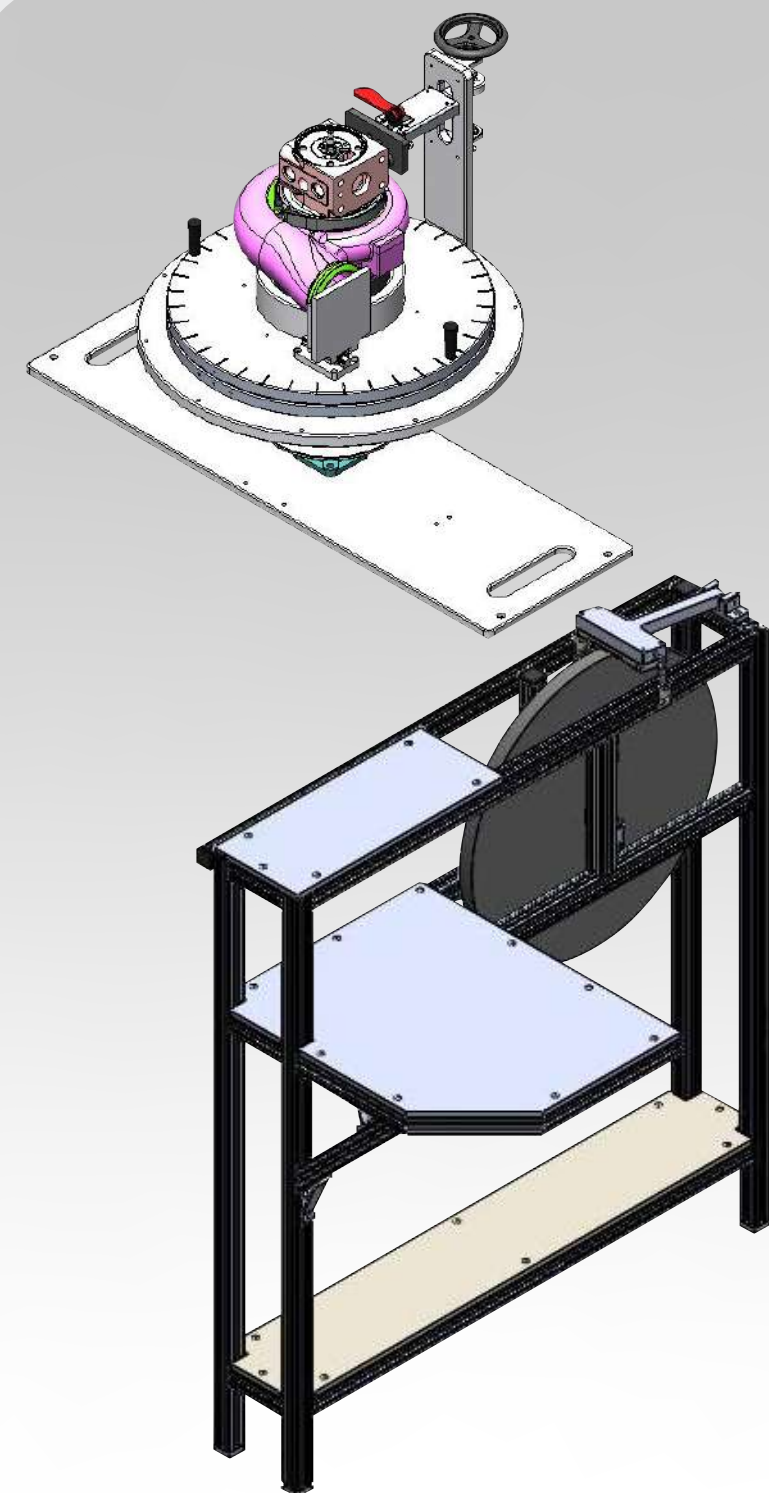

DESIGN

- 3D Models
- Workstations
- Machinery
- 2D drawings and blueprints

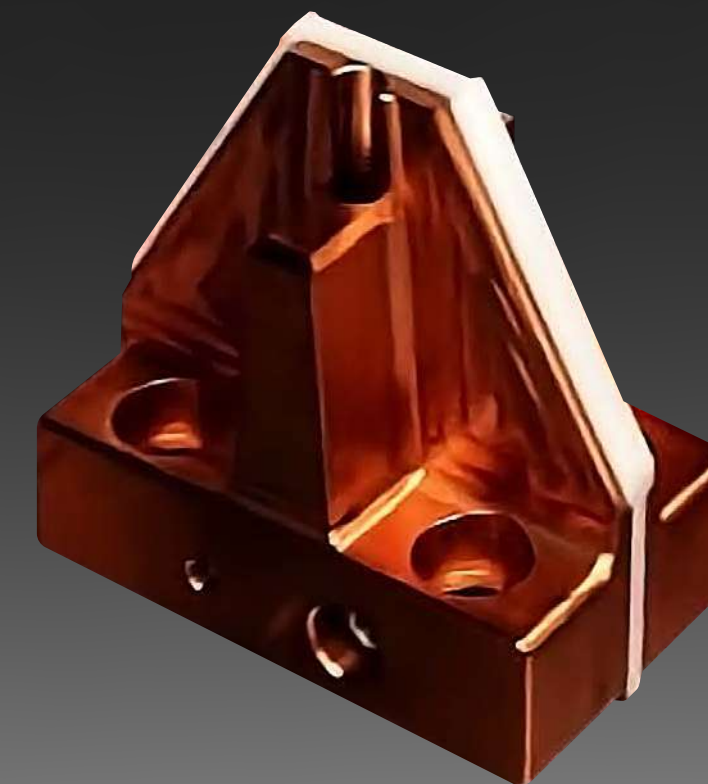

MACHINING

- Custom pieces for mechanical manufacturing.

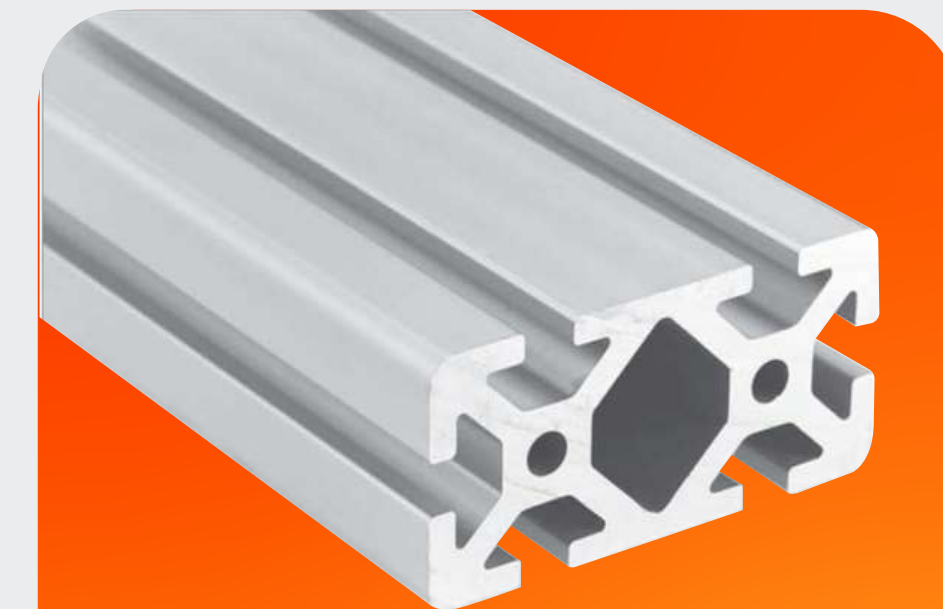

ALUMINUM PROFILES

- Aluminum profiles
- Accessories.

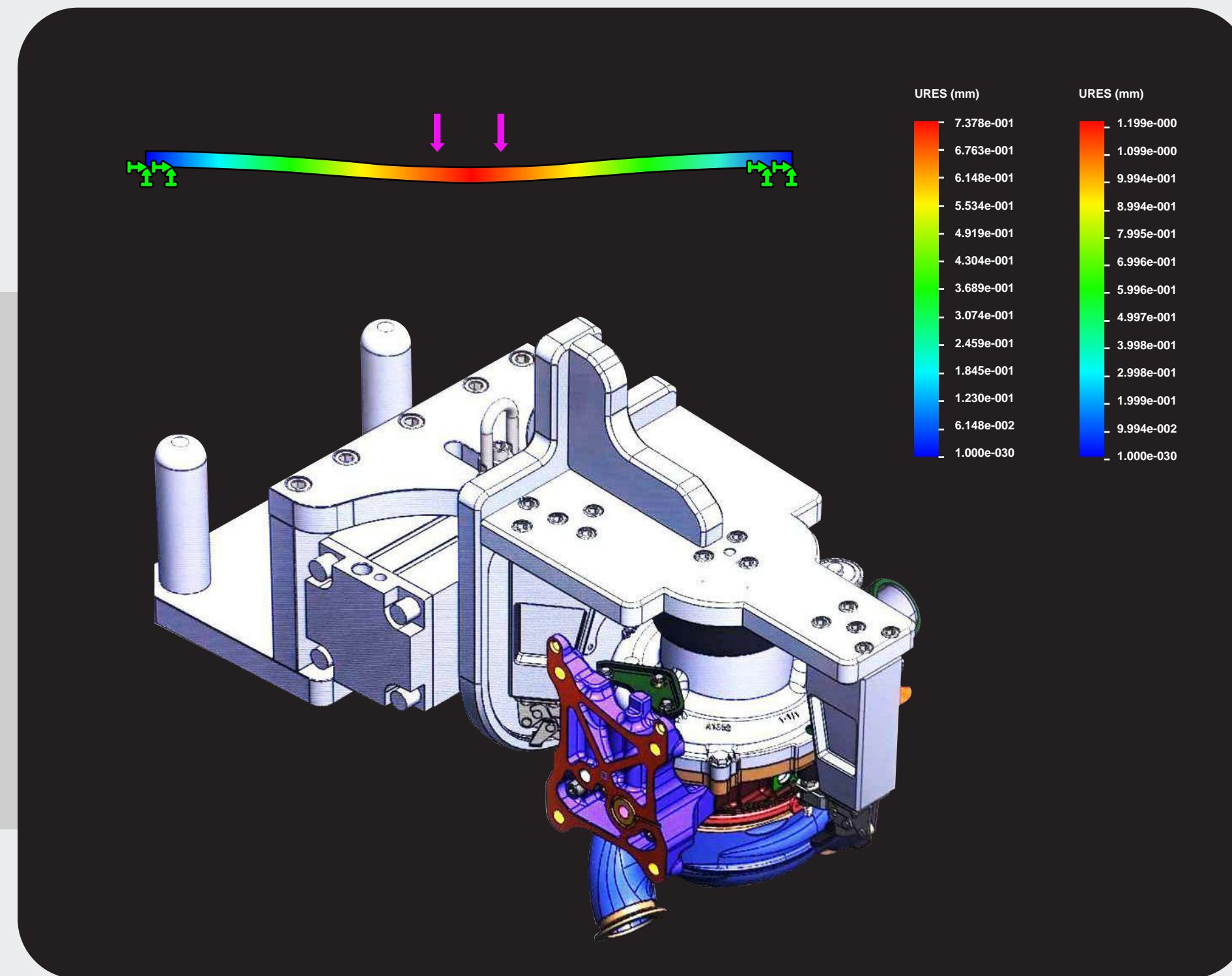

PORTFOLIO:

- 3D Design
- Simulations for personalized projects
- Machining
- Integrations
- Electric controls

STRINGER



The Stringer project is an equipment used to fabricate solar cell strings, with a modular chain length. To achieve this end result, we use a variety of technologies and tools such as; control motion, vision systems, live temperature controllers, magnetic induction, etc.

- Control motion: In this instance we use Allen Bradley's brand, with Kinetix 6000 product family, offering robust precision and reliability.
- Live temperature controller: Beckhoff PLC, with its high-resolution specs, offers temperature stability in real time and ensures optimal results and safety within its welding processes.
- Temperature induction: As an induction tool, CEIA coil is used as a complement to Beckhoff's control system.
- Welding paste applicator: We use Musashi as the main brand for this task, as it is a specialized, fluid pressure dispenser.

This set of pieces and tools works simultaneously, displacing the cell, aligning it, dispensing the welding paste, installing interconnectors, and welding to create, step by step, the strings used in solar panels.

This project contains the following services:

Supply of spare parts Installation services Electric control Industrial Design

Fabrications Programming Piece metrology Etc.

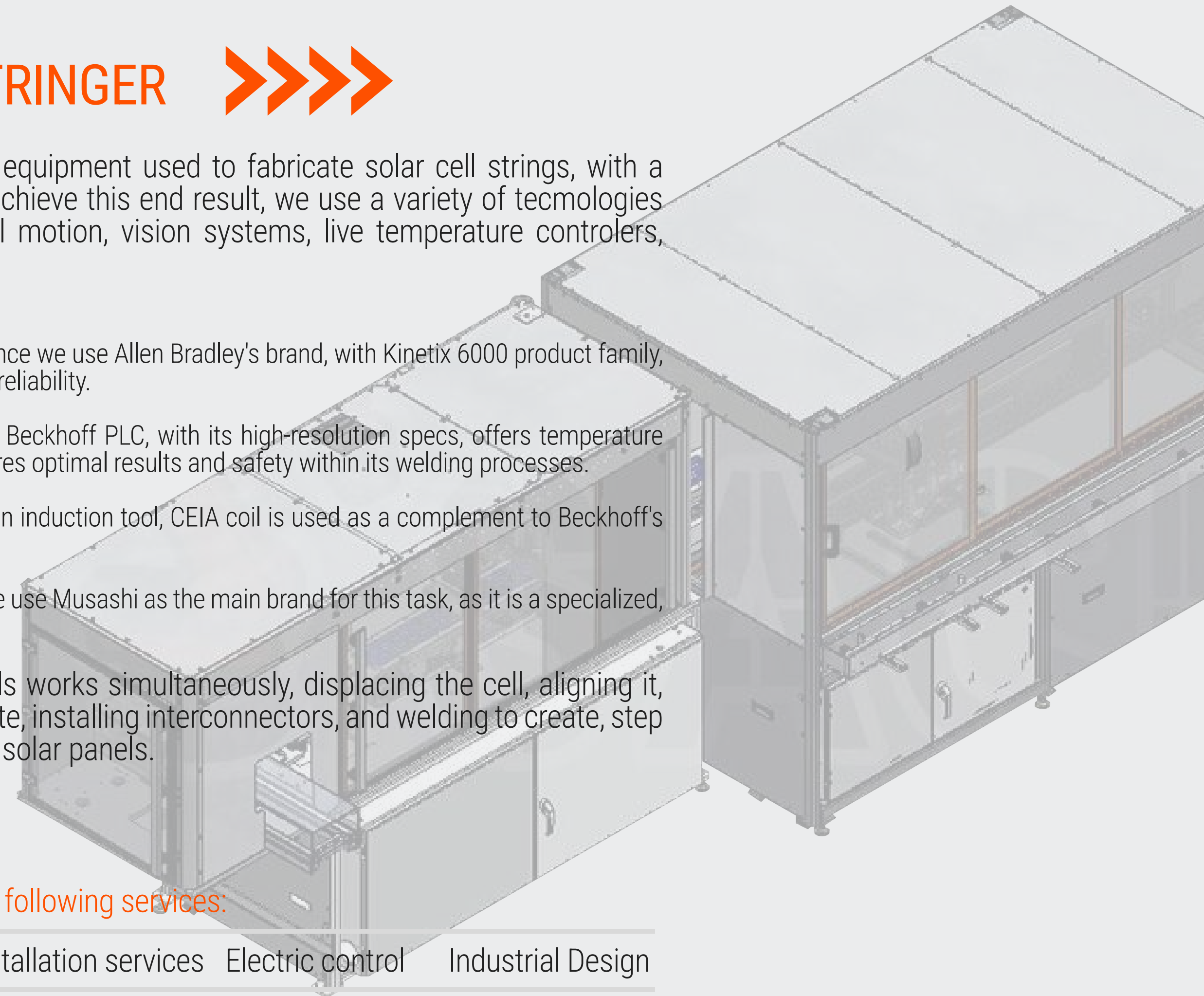
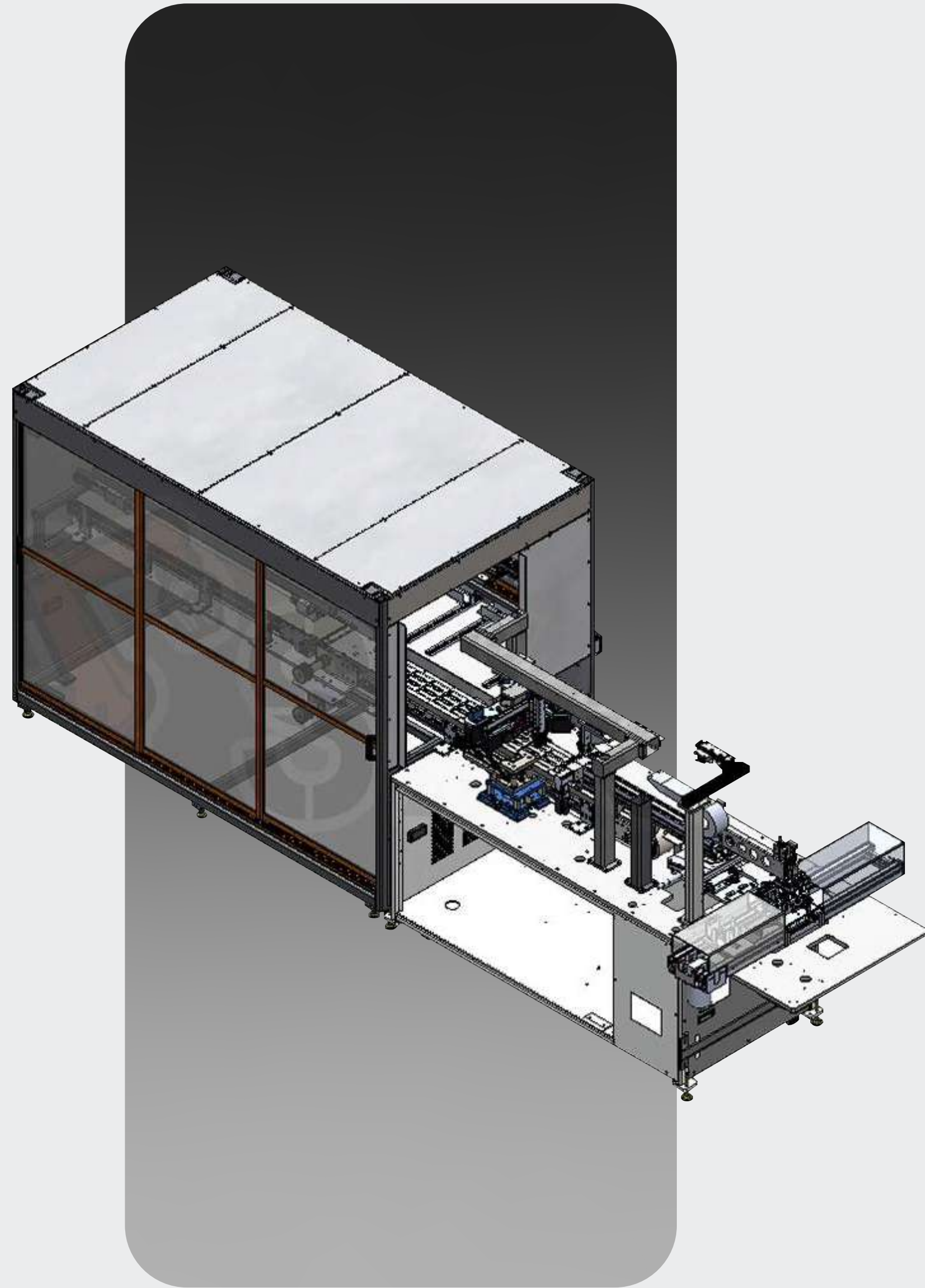



DEBURRING MACHINE



This equipment is designed for the purpose of cleaning the turbo turbine parts. This allows to enhance the appearance and functionality of the pieces. This project has:

Safety interlocks in every one of its doors, locking them in case of it being necessary, monitoring the equipment status (open/closed).

Two emergency stop buttons placed in the main control panel and on the left side of the machine. When presing, every task made by the equipment stops instantly.

Safety curtains, which monitor the station's operator actions.

Sick systems, a safety device that monitors inputs and actuates outputs, and under certain conditions interrupts equipment's actions, cutting voltage power from all motor drivers, ceasing power to safety valves and to the outputs of the pneumatic actuators. To restore operations from the system, all safety devices must display the 'ok' status, including interlocks, emergency stops and safety curtains.

The deburring machine has two energy isolation points. The electric isolation point is found outside, at the cabinet disconnect switch. The pneumatic isolation point is located on the pneumatica panel. It is important to close it when handling the machine, and to make use of the tag out & lock out procedure to avoid unintended actions from the equipment.

This project contains the following services:

Safety devices

Machining

Electrical control

Industrial design

Programming

etc.



PARTNERSHIPS

OUR CLIENTES



OUR SUPPLIERS

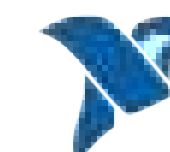
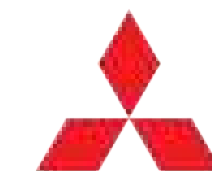

Sensor Intelligence.





SUPPLIES

OUR SERVICES:

01

Supplies, spare parts and general goods for the industrial sector, and any other general commercial area.

02

Specific material acquirement for maintenance, repairs and operational purpose.

03

We specialize in supply sales and special components from **national and international brands**.

04

Direct and indirect distributions.



AUTOMATION SUPPLIES:

- Actuators
- Industrial shock absorbers
- Cylinders
- Aluminum structures
- Connectors and accessories
- Controllers
- Hydraulic devices
- Accessories
- Hoses
- Pressure regulators
- Solenoid valves
- Clamping devices

ELECTRIC CONTROL SUPPLIES:

- Terminal blocks
- Industrial push-button stations
- Cables
- General tools
- Programmable controllers
- Fuses and accessories
- Enclosures and accessories
- Process control and measuring
- Test and measuring instruments
- Relays
- Limit switches
- Sensors
- Variable frequency drives (VFDs)
- Timers
- Industrial screens and PCs
- Discontinued products
- Power products
- Wire management tools
- Safety devices
- Motors & servomotors

PNEUMATIC SUPPLIES:

- Actuators
- Cylinders
- Clamping devices
- Air filters and regulators
- Connectors
- Electropneumatics
- Hoses
- Regulators
- Valves
- Vacuum cups

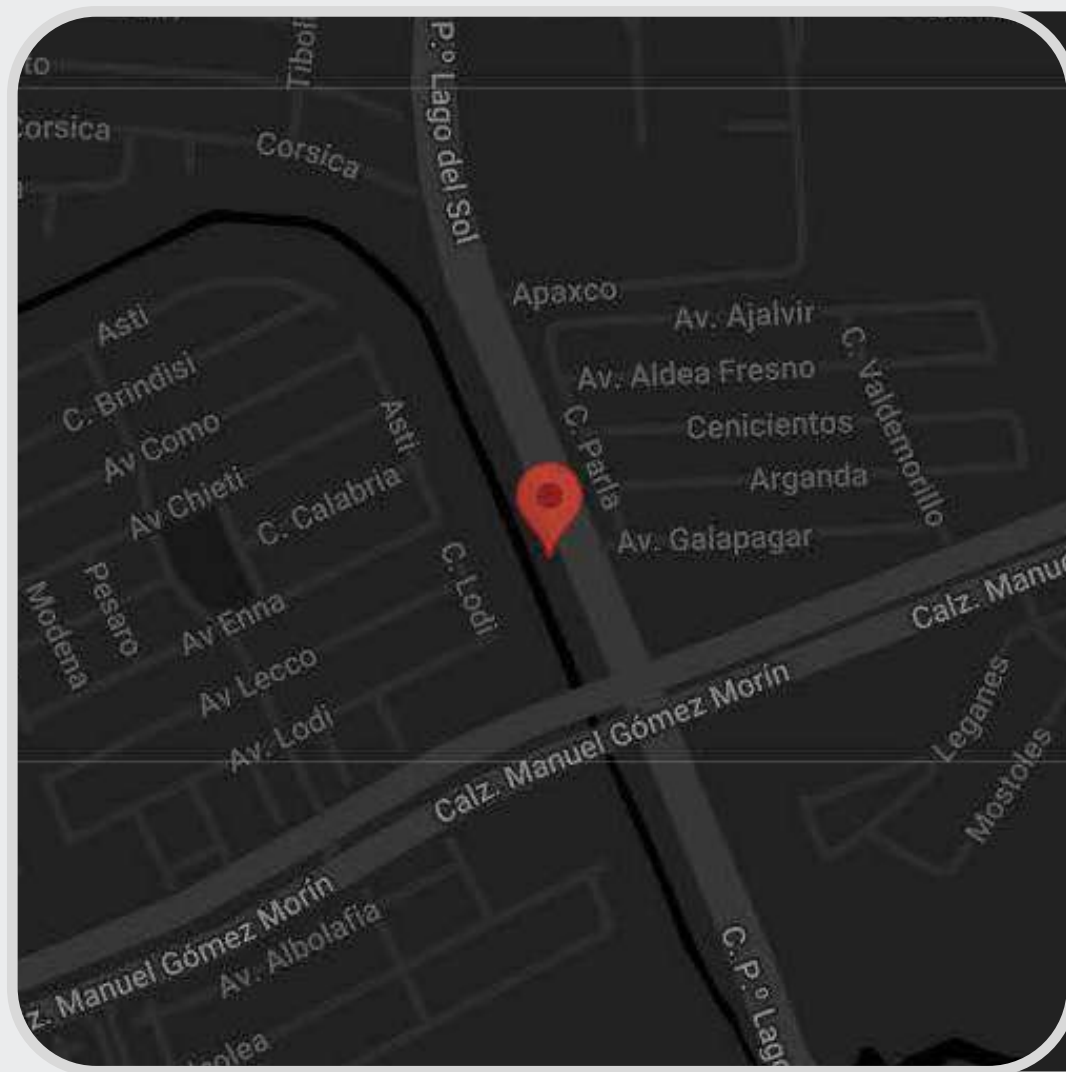

GRANADA

ADDRESS:
Lago del sol #469 Fraccionamiento Madrid
P.C. 21353

ESTIMATED DIMENSIONS:
463 m²

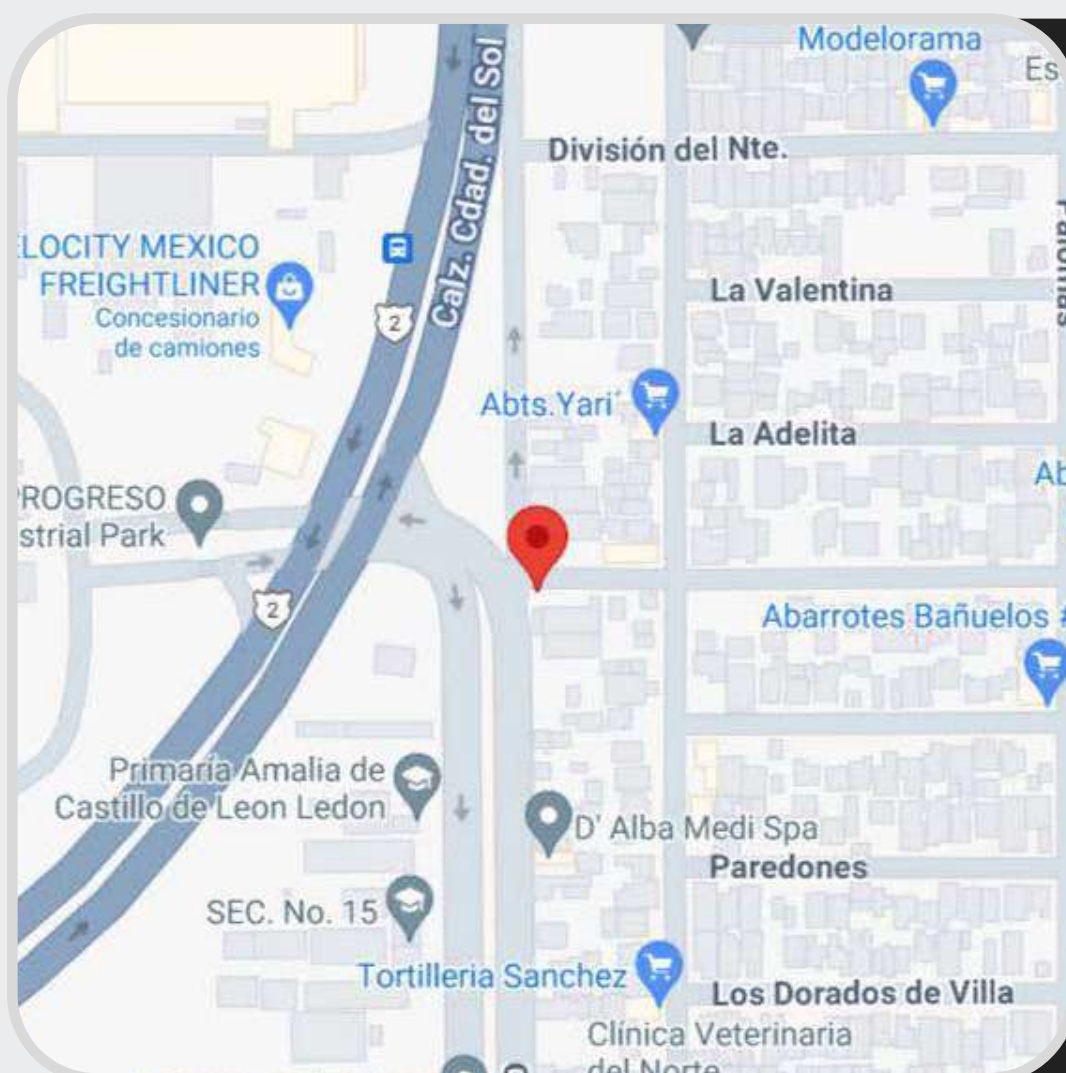

CALLE 11

ADDRESS:
Calle heróico colegio militar 2407 Colonia
división del Norte P.C. 21300

ESTIMATED DIMENSIONS:
1000 m²

CONTACTS

MAIN LINE:

(686) 281-0077

E-MAIL:

info@sacicorp.com o ventas@sacicorp.com

WEB PAGE:

sacicorp.com/



OUR SITE!